

目录

1 适用范围 Scope	2
2 术语 Glossary	2
3 型号说明 Part Number System.....	2
4 安规认证 Agency Approvals	2
5 技术参数 Specifications.....	3
6. 结构尺寸 Structure and Dimension	4
6.1 应用示意图 Application Schematic	4
7 检验 Inspection.....	5
7.1 大气条件 Atmospheric Conditions	5
7.2 机械特性 Mechanical Performances.....	5
7.3 常规检验项目 Routine Inspection Items	5
7.4 动作负载试验 Operating Duty Test.....	5
7.5 电压保护水平测试 Voltage Protection Level Test.....	6
8 安装使用及维护 Installation and maintenance.....	6
9 标示 Marks	6
10. 包装 Packaging.....	6

1 适用范围 Scope

EZ20MF277M-(G)-TB, 适用于 90V~305V AC 交流电系统。
 防电涌等级: IEC 61643-11 : 复合冲击波(Uoc/lcw) · 20kV/10kA ;
 温度范围 : -40°C ~ 105°C

EZ20MF277M-(G)-TB, are apply to 90V~305V AC system.
 Surge protection level: IEC 61643-11 : Combination impulse wave, 20kV/10kA ;
 Temperature : -40°C ~ 105°C.



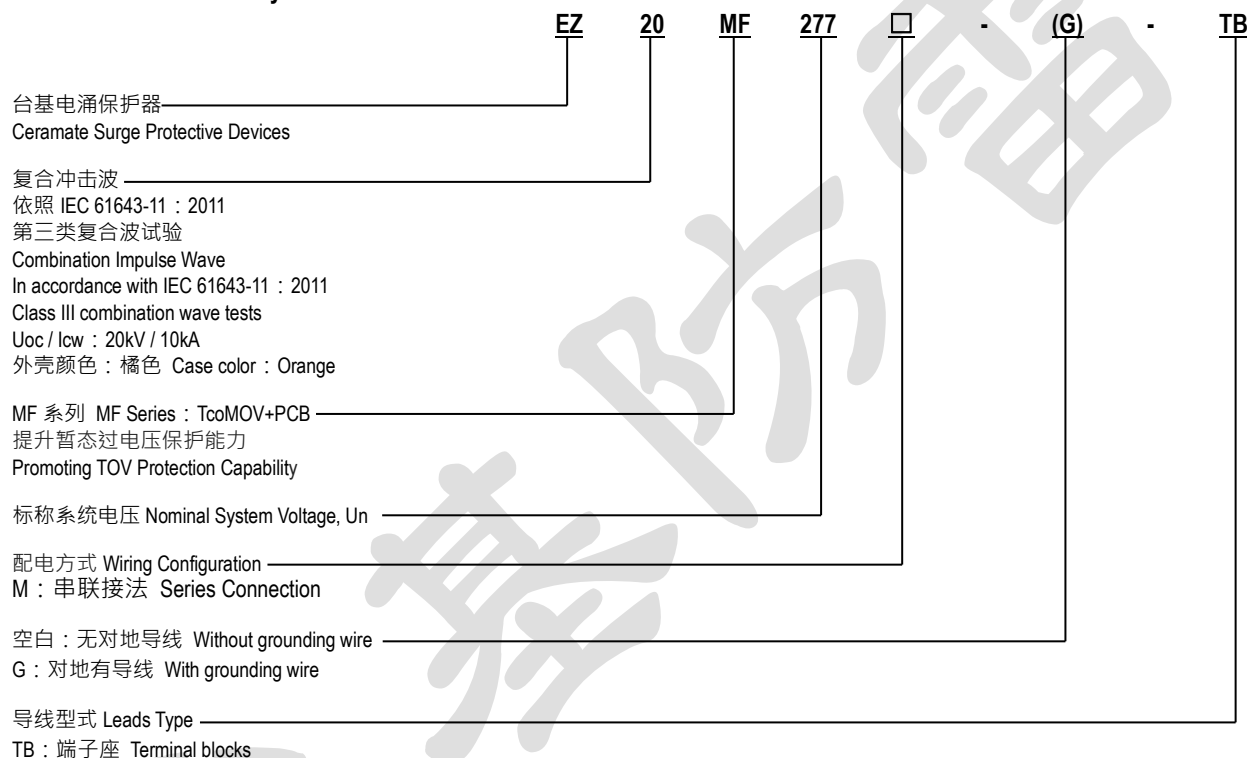

2 术语 Glossary

参考标准 Reference Standards
 IEC 61643-11:2011 · EN61643-11 : 2012+A11 · GB/T 18802.11-2020
 UL1449 4th ed.: 2018

3 型号说明 Part Number System



4 安规认证 Agency Approvals

认证机构 Agency	标准 Standards	认证号 File NO.	类别 Category	执行标准 Designed to Standards
 CQC	GB/T18802.11-2020	CQC20123254421	Ⅲ类 Class III	● GB/T18802.11-2020 ● UL 1449 4 th Ed : 2018 ● IEC 61643-11 : 2011 ● EN 61643-11 : 2012+A11 ● IEC 61000-4-5 : 2014 ● IEEE C62.41.2-2002
 TUV	低压指令 Low Voltage Directive 2014/35/EU	AN 50476855	附录 I Annex I	
 TUV	IEC 61643-11 : 2011	HU-002972	Ⅲ类 Class III	
 TUV	EN 61643-11 : 2012+A11	R50475234	Ⅲ类 Class III	

5 技术参数 Specifications

产品型号 Product Model	EZ20MF277M-TB		EZ20MF277M-G-TB	
温湿度范围 Temperature and Humidity Range	温度：-40°C至 105°C / 湿度：5%至 95%RH Temperature：-40°C to 105°C / Humidity：5%~95% RH			
端口数量 Number of Ports	一端口,输入/输出 one port, input/output			
配电系统 Power Distribution System	TN			
标称系统电压范围 Nominal System Voltage Range, Un	90VAC~305VAC			
最大连续工作电压 Maximum Continuous Operating Voltage, Uc	320VAC			
工作频率 Working Frequency	50/60 Hz			
复合冲击波 · IEC 61643-11 Combination Impulse Wave Uoc (1.2 / 50 us) / Icw (8 / 20 us)	20kV / 10kA			
电压保护水平 Voltage Protection Level , Up (V) 复合冲击波 · IEC 61643-11 Combination Impulse Wave Uoc (1.2 / 50 us) / Icw (8 / 20 us)	L-N	1500	1500	
	L-G	—	2600	
	N-G	—	1500	
额定负载电流 Rated Load Current, I _L (A)	5			
安全失效模式 Safe Failure Mode	开路模式 Open Circuit Mode (OCM)			
暂态过电压特性, 低压系统故障 Temporary Overvoltage (TOV) Characteristic, LV-system Faults	(1) 335 Vac, 5 秒, 耐受模式 5 sec, withstand mode (2) 440 Vac, 120 分钟, 耐受或安全失效模式 120min, withstand mode or safe failure mode			
预期短路电流 Prospective Short-circuit Current, I _{sccr} (A)	300			
脱离器动作指示 Indication of Disconnecter Operation	LED 指示灯由亮变灭, AC 电源断开. LED 常态有保护时亮. LED indicator from light on to light off, and AC network cut-off. Under protected LED normally on.			

备注 1: 电涌保护器安装于受试设备后,

- 依照 IEC 61643-11 : 2011, III类,
或依照 IEC 61000-4-5 : 2014
- 测试波形: 复合波;
 - 同一只产品同时满足.
 - 差模: L-N, 10kV/5kA, 2 ohm
 - 共模: L-G / N-G, 10 kV / 833 A, 12 ohm
 - 浪涌次数 (对各耦合路径): 应分别在 0°, 90°, 180° 与 270°
相角施加正、负极性各 5 次;
 - 连续脉冲间的时间间隔: 1 分钟或更短;
 - 耦合阻抗: 差模 18 μF · 共模 9 μF + 10 Ω。

Note 1: After installed SPD in EUT,

- in according to IEC 61643-11 : 2011, class III,
or in according to IEC 61000-4-5 : 2014
- test waveform: combination wave;
 - the same sample be satisfied to.
 - Differential mode : L-N, 10kV/5kA, 2 ohm
 - Common mode : L-G / N-G, 10 kV / 833 A, 12ohm
 - number of impulses (for each coupling path): five positive and five
negative impulses each at 0°, 90°, 180° and at 270°;
 - time between successive impulses: 1 min or less;
 - coupling impedance: differential mode 18 μF,
common mode 9 μF + 10 Ω.

6. 结构尺寸 Structure and Dimension

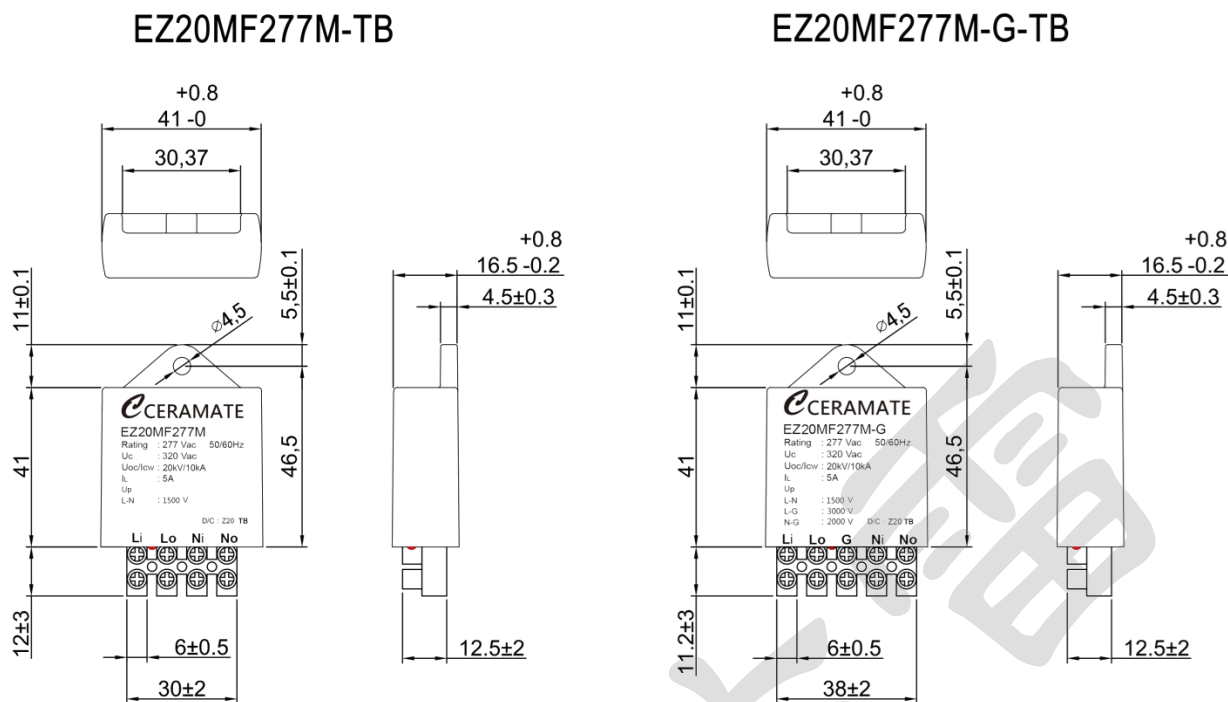

6.1 应用示意图 Application Schematic

串联接法 Series Connection 无对地 Without Ground

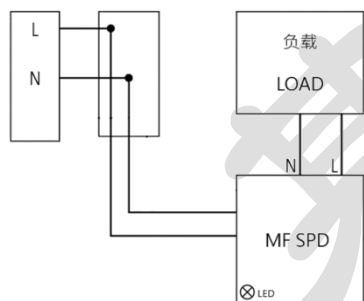

EZ20MF277M-TB

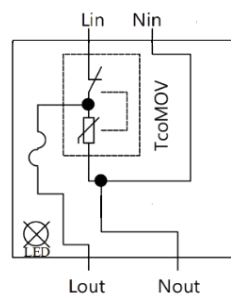

串联接法 Series Connection

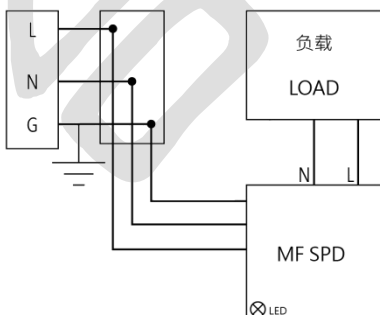

EZ20MF277M-G-TB

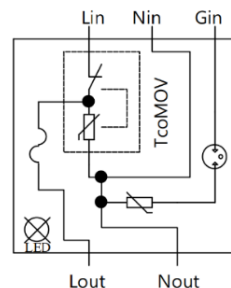

备注: 1. LED 常态有保护时亮。 Note: 1. Under protected LED normally on.

7 检验 Inspection
7.1 大气条件 Atmospheric Conditions

温度 Temperature : 5 °C - 35 °C

相对湿度 Relative Humidity : 25%-75%

大气压力 Air pressure: 86 kPa to 106 kPa

7.2 机械特性 Mechanical Performances

项目 Items	试验方法 Test methods/conditions	参考标准 Reference Standards	抽样频率和 接受标准 AQL
拉力 Pull	将待测试产品安装于测试架上,所有输入或输出导线从任意角度施加总重 89N(20 磅)的法码挂钩绑牢,受力时间 1 分钟,轻放法码。 Install the product on the test shelf and tie all input or output lead wires respectively with 89N(20 lbf) weight from any angle for 1 minute. Then release the weights slightly.	IEC 61643-11 GB/T 18802.11	3 pcs/Lot, AC=0 导线不损伤、脱落。 The lead wires shouldn't be damaged.

7.3 常规检验项目 Routine Inspection Items

序号 No.	项目 Items	试验要求 Test Requirements	参考标准 Reference Standards	抽样频率和 接受标准 AQL
1	外观 Appearance	壳体无穿孔,飞边;引脚镀层良好,无氧化发黑等情况。 The case without perforation, flash, the pin coating is good and no oxidative blackening.	ISO 2768-1 GB/T 1804	G-II, AQL=1.0
2	尺寸 Dimension	用游标卡尺测量引脚外露长度,尺寸范围参照 6。 Use vernier caliper to measure the Pin out length, size range reference 6..	ISO 2768-1 GB/T 1804	S-2, AQL=0.65
3	介电耐压 Dielectric Withstand	在引脚和外壳间施加工频电压≥2200 V, 1 分钟,不应该发生闪络和击穿 Subject the voltage no less than 2200 V, last for 1 minute between leads and enclosure, arcing or puncturing shall not occur.	IEC 61643-11 GB/T 18802.11	S-2, AQL=1.0
4	动作负载试验 Operating Duty Test	参见第 7 章节《检验》第 7.4 条 Reference 7.4 of the chapter 7 《Inspection》	IEC 61643-11 GB/T 18802.11	3 PCS/Lot AC=0
5	电压保护水平测试 Voltage Protection Level Test	参见第 7 章节《检验》第 7.5 条 Reference 7.5 of the chapter 7 《Inspection》	IEC 61643-11 GB/T 18802.11	3 PCS/Lot AC=0

7.4 动作负载试验 Operating Duty Test

测试方法:将防雷器接入测试端,冲击 2 次 U_{oc} (正、负极各 1 次)测试限制电压,再施加 15 次 U_{oc} 冲击,分成 3 组,每组 5 次冲击。两次冲击之间的间隔时间为 50s~60s,两组之间的间隔时间为 30min。两组冲击之间样品无需施加电压。在施加每组冲击之后,需继续加电至少一分钟来检查复燃。在最后一组冲击和继续加电一分种后,SPD 保持加电,或在少于 30 秒内加电到 U_c ,保持 15 分钟来检查稳定性。30 分钟后再重复进行测试限制电压的程序。

Test Method: Terminal wires of the SPD shall be subjected to one sequence of positive polarity and one sequence of negative polarity at U_{oc} to determine the measured limiting voltage. And then three groups of five impulses of U_{oc} impulses with positive polarity shall be applied. The interval between the impulses is 50 s ~ 60 s, the interval between the groups is 30 min. It is not required that the test sample is energized between the groups. The SPD shall be energized at U_c . After the application of each group of impulses, the SPD shall remain energized without interruption for at least 1 min to check for reignition. After the last group of impulses and the 1 min period the SPD either remains applied or is reapplied within less than 30 s to U_c for another 15 min to check for stability. 30 minutes later, the SPD shall be subjected to sequences to determine the measured limiting voltage repeatedly.

判定标准:产品在测试中不能有可见可闻的损坏,测试前后限制电压的变化率<10%。

Pass Criteria: During and following the surge test, there shall not have visible or smelt (or both) damage, and the rate of the clamping voltage's variation shall be less than 10%.

7.5 电压保护水平测试 Voltage Protection Level Test

测试方法：将防雷器接入测试端，冲击4次Uoc（正、负极性各2次）测试限制电压；若是回路中有GDT时，应依次施加峰值约为0.1；0.2；0.5；1.0的Uoc冲击电压（正、负极性各2次）测试限制电压。每次冲击的间隔时间应足以使样品冷却到环境温度。

Test Method: Terminal wires of the SPD shall be subjected to one sequence of positive polarity and one sequence of negative polarity to determine the measured limiting voltage; If there is a GDT component in the circuit, 8/20 current impulses with two sequence of crest values of approximately 0,1; 0,2; 0,5; 1,0 times In shall be applied to determine the measured limiting voltage. After each impulse, the rest time should be let samples cooled to the ambient temperature.

判定标准：电压和电流波形图及目测检测样品应没有击穿或闪络的现象；试验过程中不应发生可见损害；不对人员或设备产生爆炸或其他危险；试验后样品Uoc测试时的限制电压值小于或等于Up。

Pass Criteria: Voltage and current records and visual inspection shall show no indication of puncture or flashover. No visible damage shall occur during the test. Values for measured limiting voltage after the test of Uoc shall be below or equal to Up.

8 安装使用及维护 Installation and maintenance
8.1 EZ20MF277M-(G)-TB 串联接法，一端口，输入/输出。

EZ20MF277M-(G)-TB Series connection one port, input / output.

8.2 不正确的安装可能会损坏 SPD 的性能，严格按照指示安装尤为重要。

Incorrect installation may damage the performance of the SPD, and it is especially important to follow the instructions.

8.3 在开始安装程序之前，需用电表验证工作电压(AC 或 DC)，以确保工作电压符合要求。

Before starting the installation procedure, use the meter to verify the operating voltage (AC or DC) to ensure that the operating voltage meets the requirements.

8.4 如果测量的电压超过电涌保护器的额定值，请勿安装 SPD。

Do not install SPD if the measured voltage exceeds the rating of the surge protector.

8.5 安装前不要接入电力系统。

Do not connect the power system before installation.

8.6 该电涌保护器在通电时 LED 灯应亮，如果 LED 灯不亮，说明电涌保护器已经损坏，需维修或更换。

The LED indicator should be light up when the surge protector is energized. If the LED indicator does not light, it indicates that the surge protector is damaged and needs to be repaired or replaced.

9 标示 Marks
9.1 本体标示 Product Body Marking:
EZ20MF277M-TB
EZ20MF277M-G-TB

10. 包装 Packaging

待确定 To be determined

-以下无正文 **END**